

### PRODUCT DETAILS

The BIANCO FCT150M is a robust cast iron, twin impeller, horizontal end suction centrifugal pump. Manufactured using high quality materials and components BIANCO FC Series are quiet and reliable offering 'best in class' high performance operation.

### APPLICATIONS

- Ideal for use in small-scale agriculture, horticulture or other limited industrial services
- Wash-down, tank filling, HVAC, circulation, fire suppression, pressure boosting.

### FEATURES

- 240V single phase TEFC motor with in-built auto reset thermal overload to prevent pump from damage
- 2m H07 power cable with IEC type I Au/NZ 15 amp 3 pin plug
- Excellent motor and hydraulic efficiency
- Electrochemical **cataphoresis** treatment applied to the pump body for enhanced corrosion resistance

To protect the pump from excessive cycling and to isolate from the effects of water hammer, adding a pressure tank to the system is highly recommended



### TECHNICAL DATA

<b>RATED POWER (P2)</b>	1.5kW (2.0hp)
<b>MAX. FLOW [LPM]</b>	160 LPM
<b>MAX. HEAD [M]</b>	57.5m
<b>MAX. PRESSURE RATING</b>	8 bar
<b>FLUID TEMP RANGE</b>	4 - 60 deg C
<b>MAX. AMBIENT TEMP</b>	40 deg C
<b>MOTOR RATING</b>	Continuous
<b>MOTOR INSULATION</b>	Class F
<b>PUMP BODY</b>	Cast Iron HT200
<b>MOTOR SHAFT AND IMPELLER</b>	304 grade stainless steel
<b>MECHANICAL SEAL</b>	Carbon / Ceramic
<b>O RINGS</b>	Nitrile

<b>RATED VOLTAGE (V)</b>	1 ph 220 (-6%) to 240V (+6%) 50 hz
<b>RATED CURRENT (A)</b>	11.5A
<b>RATED SPEED (RPM)</b>	2800 - 2 pole
<b>MOTOR TYPE</b>	Asynchronous, TEFC
<b>IP RATING</b>	I.P. 44
<b>SUCTION CONNECTION</b>	1 1/2" BSPF
<b>DISCHARGE CONNECTION</b>	1" BSPF
<b>AUTOMATIC OPERATION</b>	No - bare pump only
<b>MOTOR PROTECTION</b>	Auto re-setting thermal overload
<b>CAPACITOR</b>	45uF 450V +/- 5%
<b>CARTON DIMENSIONS</b>	445mm L x 255mm W x 300mm H
<b>GROSS WEIGHT (KG)</b>	28kg

### CURVE

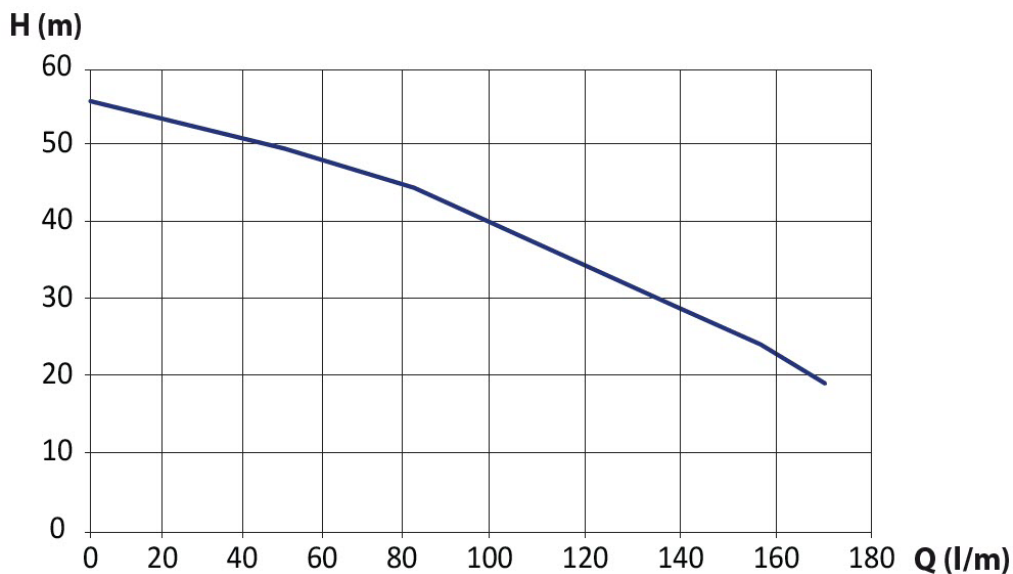

### DIMENSIONS

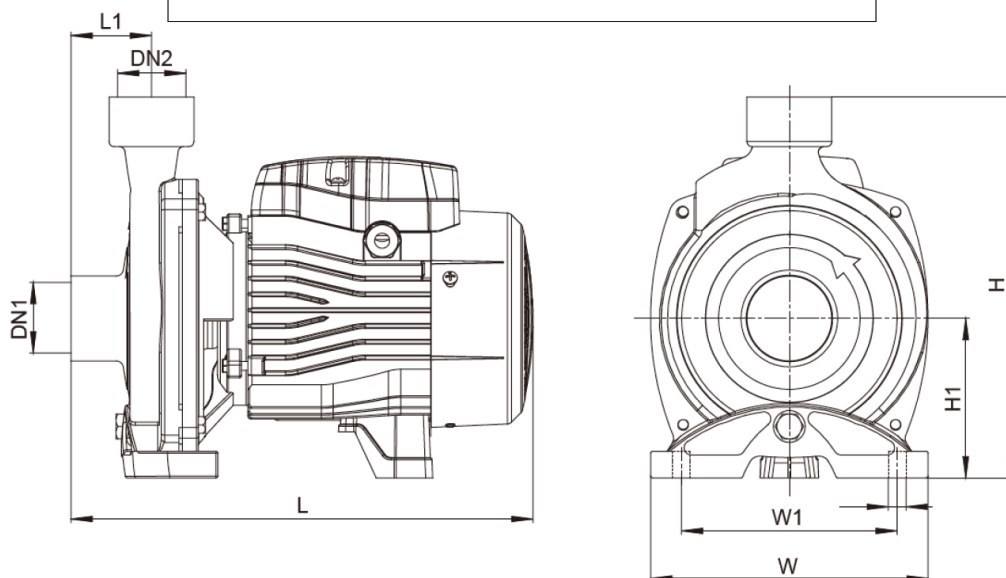

MODEL	L	W	H	L1	W1	H1	Bolt Hole Ø	DN1	DN2
BIA - FCT150M	400mm	225mm	262mm	80mm	185mm	112mm	10mm	1 1/2" BSPF In	1" BSPF Out

### WARRANTY / CERTIFICATIONS

